

Arad.

Novos

Yu ISSN 0350-2708

JUGOSLOVENSKO DRUŠTVO ZA MEHANIKU

teorijska i primenjena
mehanika

BEOGRAD, 1975.



Теоретическая и прикладная механика является органом Югославского общества по механике для публикации оригинальных научных трудов членов общества и других соответствующих научных работ по Теоретической механике и по её приложениям в других науках и технике.

Журнал выходит два раза в год.

Рукописи должны быть приготовлены для печати по указаниям которые находятся на задней стороне обертки и присланы на следующий адрес: Югославское общество по механике, Кнеза Милоша 9, 11000 Београд, Югославия.

Научные институции, академии наук, научные общества и издательственные учреждения из области научной литературы, желающие совершать обмен с этим журналом, должны обратиться по адресу: Природно-математички факултет, Институт механике, пошт. преградак 550, 11000 Београд, Югославия.

Все труды подлежат рецензии и постановлению Редакционного совета окончательно.

„Theoretical and applied mechanics“ is the official periodical of the Yugoslav Society of Mechanics for publishing of original scientific papers of members of the Society and other corresponding scientific papers from the field of Theoretical mechanics and its applications to other sciences.

This periodical comes out twice a year.

Manuscripts for publishing have to be prepared according to the propositions given on the back cover and have to be sent to the following address: Jugoslovensko društvo za mehaniku, Kneza Miloša 9, 11000 BEOGRAD, Yugoslavia.

Scientific institutions, Science academies, scientific societies and publishing houses in the field of sciences that are interested to exchange their publications for this periodical, are to write directly to the address: Prirodno-matematički fakultet, Institut za mehaniku, poštanski pregradak 550, 11000 Beograd, Yugoslavia.

All papers are bound to be reviewed and the decision of the Editing Board is final.

Редакционный совет:
АНДРЕЙЕВ Василий
ДИМИТРИЕВИЧ Димитрие
ХАЙДИН Никола
КУХЕЛЬ Антон
НАЕРЛОВИЧ-ВЕЛЬКОВИЧ
Наталия
ПОПОВ Благоя
РАДОСАВЛЈЕВИЧ Љубодраг
ВУЈИЧИЧ Велько

EDITING BOARD:
ANDREJEV Vasilij
DIMITRIJEVIĆ Dimitrije
HAJDIN Nikola
KUHELJ Anton
NAERLOVIĆ-VELJKOVIĆ Na-
talija
POPOV Blagoje
RADOSAVLJEVIĆ Ljubodrag
VUJIČIĆ Veljko

Glavni i odgovorni urednik Veljko VUJIČIĆ

Yugoslav Society of Mechanics
Югославское общество по механике

THEORETICAL AND APPLIED
MECHANICS

ТЕОРЕТИЧЕСКАЯ И ПРИКЛАДНАЯ
МЕХАНИКА

1

Beograd, 1975

ANALYSIS OF STRUCTURALLY ORTHOTROPIC PLANE SYSTEMS

R. Bareš

Much theoretical (1,5,6,11,14) and experimental (10,12,13) research has been published which has given proof that the analysis of structurally orthotropic plane structures can be successfully based on the analogy to the solution of a true, materially orthotropic plate by means of the Huber equation (9); it has also been shown that the results furnished by such an approach are reliable, unless the basic assumptions are too oversimplified. Simplicity, clarity possibility of good insight into the structure at any phase of the calculation are the main advantages of the method of analysis as derived by the present author (2,3) on the basis just described. With the author's method it is possible to take into account also the not insignificant factor of lateral contraction, which up to the present has been mostly neglected in technical calculations. The Huber equation is solved by the method of dimensionless coefficients, similarly as in (1,8,11). The values of these coefficients can be calculated beforehand, and the numerical work can be best handled by means of automatic computers. Once the coefficients have been tabulated, the analysis of any given structure with defined dimensions can easily worked out by the designer.

The structural (or shape) orthotropy of a plate is given either by different reinforcement or different degree of prestress in two mutually perpendicular direction, or by rigidly connecting the plate to beams in the longitudinal or the transverse or in both these directions, respectively. Structural orthotropy results also from intentional prevention or reduction of force transfer in the transverse direction (assembled structures of precast elements). The true plate with material orthotropy presents thus one limiting case, while in the other limiting case the structure consists only of two systems of beams (longitudinal main beams and cross beams). According to the overall arrangement as well as to the relative importance of the individual elements (plate or slab, prismatic members, etc.) the influence of torsion and lateral contraction upon the internal state of, stress varies appreciatedly.

Principles of the method

The static response of a shape orthotropic plane structure shown in fig. 1 is — when the „diaphragm“ effect is neglected — given by the Huber equation, which for the equivalent plate can be written in the form (6).

$$\rho_L \frac{\partial^4 W}{\partial X^4} + 2H \frac{\partial^4 W}{\partial X^2 \partial Y^2} + \rho_Q \frac{\partial^4 W}{\partial Y^4} = p(x, y) \quad (1)$$

where

$$2H = (\rho_L \nu_Q + \rho_Q \nu_L + \gamma_L + \gamma_Q)$$

and ρ_L , ρ_Q , γ_L , γ_Q are the unit rigidities in flexure and torsion for the longitudinal and the transverse direction, respectively. The factors ν_L and ν_Q express the stress-strain relations and their dependence on the structural anisotropy (6).

All the sectional and material properties of the structure are determined by the following three dimensionless parameters:

the parameter of lateral stiffness

$$\vartheta = \frac{b}{l} \sqrt{\frac{\rho_L}{\rho_Q}} \quad (7) \quad (\text{range } 0 \leq \vartheta \leq \infty) \quad (2)$$

the parameter of torsional stiffness

$$\alpha = \frac{\gamma_L + \gamma_Q}{2(1 - \eta) \rho_L \rho_Q} \quad (11) \quad (\text{range } 0 \leq \alpha \leq 1) \quad (3)$$

and

the parameter of lateral contraction

$$\eta = \nu_L \sqrt{\frac{\rho_Q}{\rho_L}} \quad (2,3) \quad (\text{range } 0 \leq \eta \leq 0,5) \quad (4)$$

Using the factors α and η we can write

$$2H = 2\epsilon \sqrt{\rho_L \rho_Q} \quad (5)$$

where

$$\epsilon = [\eta + \alpha(1 - \epsilon)]$$

denotes the parameter of the middle term in the Huber equation ($0 \leq \epsilon \leq 1$). The location of the point where the effects are required and the location of a

point-load are given by the dimensionless coordinates

$$\varphi = \frac{\pi y}{b}, \quad \xi = \frac{\pi x}{l}, \quad \text{and} \quad \psi = \frac{\pi z}{b}$$

The solution of the governing Huber equation follows on the same pattern as has been derived in (1); here, however, the factor η is consistently taken into account in the governing equation (in the factors $\rho_Q, \rho_L, 2H$), as well as in boundary conditions (along the free edges) and in the expressions for internal stress components $M_L, M_Q, M_{LQ}, M_{QL}, Q_L, Q_Q, Q_{LQ}$, the latter components being expressed in terms of the derivatives to the deflection w (9). On performing the necessary operations and simplifying, we obtain for the system according to fig. 1, which is subjected to a line load parallel to X , the following expressions for the deflection and for the stress components:

the deflection

$$W_{(x,y)} = \sum_m \frac{p_m l^4}{2bm^4 \pi^3 \rho_L} K_{(y)_m} \sin \frac{m\pi x}{l} \quad (6)$$

the bending moment in longitudinal direction

$$M_L = \sum_m \frac{p_m l^2}{2b\pi m^2} \{ K_{(y)_m} + \eta \mu_{(y)_m} \} \sin \frac{m\pi x}{l}, \quad (7)$$

the bending moment in transverse direction

$$M_Q = \sum_m \frac{p_m l}{2\theta^2 m^2 \pi} [\eta K_{(y)_m} + \mu_{(y)_m}] \sin \frac{m\pi x}{l}, \quad (8)$$

the difference of twisting moments

$$(M_{LQ} - M_{QL}) = \sum_m (1 - \eta) \frac{p_m l}{2\pi m} [\tau_{(y)_m}] \cos \frac{m\pi x}{l}, \quad (9)$$

the shear force in longitudinal direction

$$Q_L = \sum_m \frac{p_m l}{2bm} \left\{ K_{(y)_m} + \left(\frac{\gamma_Q}{\sqrt{\rho_L \rho_Q}} + \eta \right) \mu_{(y)_m} \right\} \cos \frac{m\pi x}{l}, \quad (10)$$

the shear force in transverse direction

$$Q_Q = \sum_m p_m \left\{ k_{(y)_m} + \frac{1}{4} \left(\eta + \frac{\gamma_L}{\sqrt{\rho_L \rho_Q}} \right) \tau_{(y)_m} \right\} \sin \frac{m\pi x}{l}, \quad (11)$$

and, finally

$$\bar{Q}_L = \sum_m \frac{p_m l}{2bm} \{ K_{(y)_m} + (2\epsilon - \eta) \mu_{(y)_m} \} \cos \frac{m\pi x}{l} \quad (12)$$

the reactions in longitudinal direction.

In these formulas the symbols K , μ , τ , and κ are dimensionless coefficients given by the expressions

$$K_{(y)m} = \frac{m\vartheta}{\sqrt{2(1+\epsilon)}} \{ [A'_m M_{\varphi m} + \bar{B}'_m N_{\varphi m}] + [C'_m O_{\varphi m} + \bar{D}'_m P_{\varphi m}] + [O_{|\varphi-\psi| m} + aP_{|\varphi-\psi| m}] \} \quad (13)$$

$$\begin{aligned} \mu_{(y)m} = & -\frac{m\vartheta}{\sqrt{2(1+\epsilon)}} [\epsilon (A'_m M_{\varphi m} + \bar{B}'_m N_{\varphi m}) + \sqrt{1-\epsilon^2} (-A'_m N_{\varphi m} + \\ & + \bar{B}'_m M_{\varphi m}) + \epsilon (C'_m O_{\varphi m} + \bar{D}'_m P_{\varphi m}) + \sqrt{1-\epsilon^2} (C'_m P_{\varphi m} - \\ & - \bar{D}'_m O_{\varphi m}) + \sqrt{\frac{1+\epsilon}{1-\epsilon}} P_{|\varphi-\psi| m} - O_{|\varphi-\psi| m}] \end{aligned} \quad (14)$$

$$\begin{aligned} \tau_{(y)m} = & [A'_m M_{\varphi m} + \bar{B}'_m N_{\varphi m}] + \sqrt{\frac{1-\epsilon}{1+\epsilon}} [-A'_m N_{\varphi m} + \bar{B}'_m M_{\varphi m}] - \\ & - [C'_m O_{\varphi m} + \bar{D}'_m P_{\varphi m}] + \sqrt{\frac{1-\epsilon}{1+\epsilon}} [-C'_m P_{\varphi m} + \bar{D}'_m O_{\varphi m}] \mp \\ & \mp \frac{2}{\sqrt{1-\epsilon^2}} P_{|\varphi-\psi| m} \end{aligned} \quad (15)$$

$$\begin{aligned} \kappa_{(y)m} = & -\frac{1}{4} [(2\epsilon - 1)(A'_m M_{\varphi m} + \bar{B}'_m N_{\varphi m}) - (2\epsilon + 1) \sqrt{\frac{1-\epsilon}{1+\epsilon}} \cdot \\ & \cdot (A'_m N_{\varphi m} - \bar{B}'_m M_{\varphi m}) - (2\epsilon - 1)(C'_m O_{\varphi m} + \bar{D}'_m P_{\varphi m}) - (2\epsilon + 1) \sqrt{\frac{1-\epsilon}{1+\epsilon}} \cdot \\ & \cdot (C'_m P_{\varphi m} - \bar{D}'_m O_{\varphi m}) \pm (\frac{2\epsilon}{\sqrt{1-\epsilon^2}} P_{|\varphi-\psi| m} - 2O_{|\varphi-\psi| m})] \end{aligned} \quad (16)$$

Similar expressions are obtained for the case of load evenly distributed over the width, or for the case when the structure is loaded by external transverse bending moments acting along the two free edges (2,3).

It may be seen that once the dimensionless coefficients have been calculated, the rest of the calculation is quite simple, since it involves only a few algebraic operations. The dimensionless coefficients can be in any given case determined

easily by means of a computer, where the program can be once for all set up and tuned beforehand. The coefficients can be also tabulated for specified characteristic values of the governing three parameters, and in this case the analysis of any given structure can be performed using the tabulated values together with the interpolation formulas given below. When the latter procedure is applied, see (1), the calculation is facilitated by the elsewhere derived fact, that for any of the coefficients its respective value corresponding to the m - th term of the pertaining fourier series is identic to its value pertaining to the first term of the series, but written for the reduced magnitude $m \vartheta$ of the parameter of lateral stiffness. The dependence of all the coefficients on η and α can — as a futher simplification — with sufficient accuracy be expressed (for all the characteristic points φ and points of load ψ by means of the parabolic interpolation formula

$$X_k = X_{min} + (X_{max} - X_{min}) F(k)$$

where X_k denotes the required value of the coefficient, for a given value of η or/and α at a specified point φ for the load at ψ , X_{min} is the value of the coefficient for the minimum value of α and/or η at the location φ for the load applied at ψ , X_{max} is the value of the coefficient for the maximum value of α and/or η at the location φ for the load applied at ψ , $F(k)$ is a function dependent on α , η , ϑ , φ , and ψ . It is thus possible to tabulate the coefficients only for limit values of α , η for a sufficiently dense net of φ , ψ and for various values of ϑ (2,3).

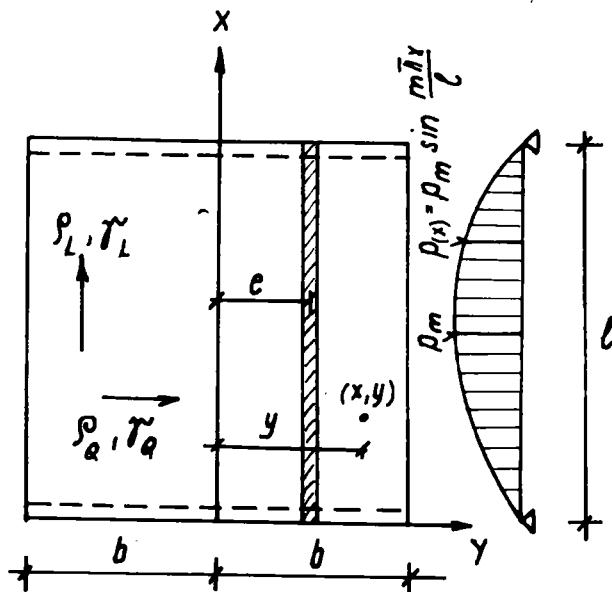

Fig. 1

If the difference of 2,5% in the true and the interpolated value is satisfactory, the factor $F(k)$ of interpolation for η (which is best done first) is $F(k) = 4$, while the factor of interpolation for α (when $\vartheta > 0,45$) is $F(k) = \sqrt{\alpha}$. For $\vartheta < 0,45$ the interpolation factors are given in the following table 1:

Table 1.

Dimensionless coefficient	Factor $F(k)$
K	$\alpha^{(-0,06 + 0,90\vartheta)}$
μ	for $\varphi \cdot \psi \leq 0$: $\alpha^{(-0,012 + 0,72\vartheta)}$ for $\varphi \cdot \psi = 0$: $\alpha^{(1,07 - 1,21\vartheta)}$
τ	for $\psi = 0$: $\alpha^{(0,075 - 1,42\vartheta)}$ for $\psi \neq 0$: $\alpha^{(-0,055 + 0,88\vartheta)}$
κ	$\alpha^{(-0,045 + 0,70\vartheta)}$

More accurate expressions for the interpolation functions $F(k)$ as well as the factors $F(k)$ for the case of evenly distributed load and for the case of external moment loading along the edges may be found in (3).

Input data

In the analysis of a given actual structure, the flexural and torsional rigidities are introduced as input, and these given values may considerably influence the results of the calculations, even more than the method itself. One of the factors which also influence the interaction and composite work of the individual elements is the factor of lateral contraction.

When the analysis is based on the concept of the equivalent plate, which replaces — in the analysis — the true system, the flexural rigidity of the plate is proportional to the flexural rigidities of the true system. These latter rigidities are of course influenced by the prevented deformations in the perpendicular direction due to the action of some of the members. This effect resembles the case when the pertaining material constant $E_{ik} = \frac{E}{1 - \nu}$ is raised; since the modulus of elasticity E (Young's modulus) itself does not change, the only change of the elastic constants E_{ik} can result from a change in the Poisson coefficients of lateral contraction; instead of the true Poisson factors ν_x, ν_y pertaining to the given structural material, the analysis is performed with their modified values ν_{Lx}, ν_{Ly} . Taking into account the influence of lateral contraction for example in the case of structure with stiffening ribs (see fig. 2), (3,4), we obtain the flexural rigidities as follows:

in the longitudinal direction

$$\rho_L = \frac{E_D J_{DX}}{b_o (1 - \nu_D^2 \left\{ \frac{d + \frac{1}{b} h_y \frac{l_1}{l_o} (b_o - b_1)}{d} | b_o \cdot \nu_{PRY} \nu_D \right\})} + \frac{E_{PRY} J_{PRX}}{b_o (1 - \nu_{PRX}^2 \frac{h_y}{h_x} \frac{l_1}{l_o} \left[\frac{5}{6} + \frac{1}{6} \frac{b_1}{b_o} \right] \frac{\nu_{PRY}}{\nu_{PRX}})}$$
(17)

in the transverse direction

$$\rho_Q = \frac{E_D J_{DY}}{l_o (1 - \nu_D^2 \left\{ \frac{d + \frac{1}{b} h_x \frac{b_1}{b_o} \frac{l_o - l_1}{l_o} \frac{\nu_{PRX}}{\nu_D} \right\})} + \frac{E_{PRY} J_{PRY}}{l_o (1 - \nu_{PRY}^2 \frac{b_1}{b_o} \left[\frac{5}{6} + \frac{1}{6} \frac{l_1}{l_o} \right] \frac{\nu_{PRX}}{\nu_{PRY}})}$$
(18)

With these values of ρ_L and ρ_Q we calculate next the parameter of lateral stiffness η .

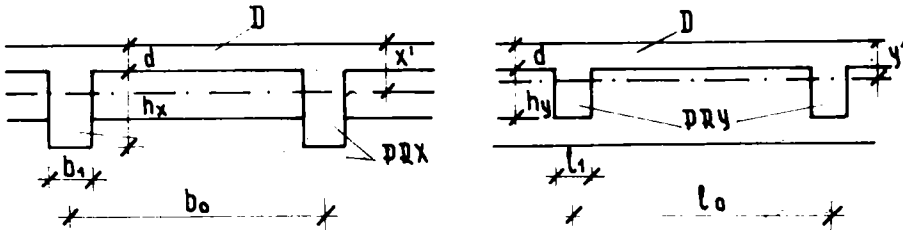

Fig. 2

Making use of the theorem of Betti (6), we introduce $\nu_Q = \nu_L \frac{\rho_Q}{\rho_L}$ and write thus $\nu_L \nu_Q = \nu_L^2 \frac{\rho_Q}{\rho_L} = \eta^2$. Then the parameter of lateral contraction η follows directly from the flexural rigidity of the equivalent

plate $\rho_L = \frac{\rho'_L}{1 - \eta^2}$, i.e. $\eta = \sqrt{\frac{\rho_L - \rho'_L}{\rho_L}}$; the factor ρ'_L is

the flexural rigidity in longitudinal direction if we assume that the Poisson factor for the material of the individual members are of zero value.

The main problem is to determine the torsional rigidity of the substitute structure in such a way as to interpret the actual conditions in the best possible manner; here we have to take into account not only the torsional rigidities of the elements but also the true flexural rigidity as a whole and also the lateral contraction. A simple investigation (2,3) (for example if we submit the limit shapes of the structure to the anticlastic test) shows immediately that simple summation of the individual torsional rigidities cannot be regarded as a satisfactory interpretation of the torsional rigidity of the structure as a whole, and the use of the sum of rigidities for instance in the strain energy methods can therefore not lead to acceptable results. The torsional rigidities and their mutual interaction are influenced by the capacity to transfer tensional or compressional stresses (the so called „fibre“ effect), as well as by the capacity to transfer bending stresses (the so called „flexural“ effect). The torsional rigidity of the substitute plate can be then expressed as (2,3)

$$\gamma_L = \frac{1}{2} \frac{1}{3} f_L^3 h_L^3 \cdot a \cdot \frac{E_D}{2(1+\eta)} \quad (19)$$

$$\gamma_Q = \frac{1}{2} \frac{1}{3} f_Q^3 h_Q^3 \cdot b \cdot \frac{E_D}{2(1+\eta)} \quad (20)$$

where a, b are the coefficients of reduction, defined as

$$a = \sqrt{\frac{\sum (M_{TRUE})_Q \cdot \rho_Q}{\sum (M_{MAX})_Q (\rho_{MAX})_Q}} \quad (\leq 1) \quad (21)$$

$$b = \sqrt{\frac{\sum (M_{TRUE})_L \rho_L}{\sum (M_{MAX})_L (\rho_{MAX})_L}} \quad (\leq 1) \quad (22)$$

Here — the symbols $\sum (M_{TRUE})_Q$ and $\sum (M_{TRUE})_L$ denote the absolute value of the sum of static moments of the actual elements located in the transverse or longitudinal section above or under the corresponding central axis, the static moments being taken with respect to the pertaining axis;

— the symbols $\sum (M_{TRUE})_Q$ and $\sum (M_{MAX})_L$ denoted the absolute value of the sum of static moments of the parts of the full slab sections, located in the transverse or longitudinal section above or under the corresponding central axis, the moments being again taken with respect to the pertaining axis;

— the factors ρ_L, ρ_Q are the flexural rigidities, calculated in the manner indicated above;

— $(\rho_{max})_Q = (\rho_{max})_L$ is the flexural rigidity of the full slab whose depth is equal to the maximum depth of the true structural section.

With these values of γ together with the factors ρ, η found above we are able to calculate the dimensionless parameter α .

To illustrate the case we have shown in fig. 3 the variation of the torsional parameter α for a concrete slab stiffened by differently spaced and differently deep ribs. It may be seen that simply cutting the slab (cuts of infinitesimal width) to the depth equal to some 4/5 of overall depth, the parameter is reduced up to less than one third of the original value, though the volume of the structure has not been changed. Also with increased spacing of the longitudinal and transverse beams the values of α decreases rapidly. For example when the depth of the longitudinal and the transverse beams is the same, and $b_o/b_1 = l_o/l_1 = 5$, then — for the slab depth equal to 1/5 of the overall depth — the torsional parameter α is approximately equal to 1/3, while with the usual assumption (i.e. summing up the individual rigidities of the elements and then distributing the obtained value over the width and length of the structure) the torsional rigidity is obtained considerably smaller (up to 0,1 approximately). Of great influence is naturally the decreasing of depth of the transverse beams; thus for the limit case that the transverse stiffness is due only to the slab (i.e. there are no transverse beams) and when the longitudinal beams are wide apart ($b_o/b_1 = 8$) we find that the minimum value of lateral stiffness is $\alpha = 0,12$. All the above given values of α are much better in accordance with experimental results obtained by the anticlastic tests, than the α values calculated with the usual methods.

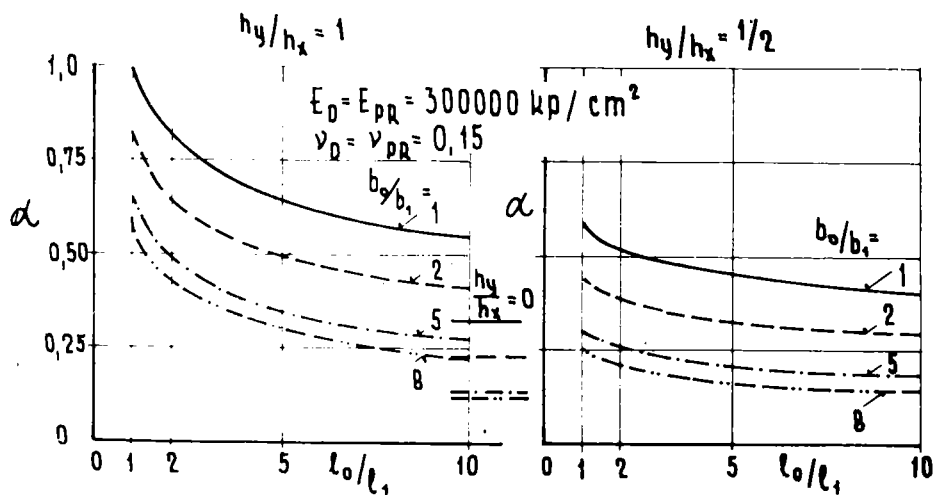

Fig. 3

Effect of lateral contraction

When the lateral contraction, as expressed by the parameter η , is neglected in constants of integration (pertaining to the solution of the governing equation) as well as in the expressions for the respective internal stress components, this result in certain errors, which can be defined by a method derived by the author; thus also the magnitude of error implicated in the existing usual methods of analysis can be ascertained. By a suitable transformation of formulas (6)–(12) for the internal stress components it is possible to find the magnitude of error which arises due to neglecting the parameter in the governing equation and in the boundary conditions, or which arises due to neglecting the parameter η only in the formulas for internal stress components, or – finally – the error which results if η is neglected throughout. In the table 2 below we have given the maximum errors for the internal stress components (reduced weighted average according to the relative weight of the individual stress components for specified values of ϑ and α) which arise due to neglecting the parameter η ; the errors have been related to the chosen value $\eta = 0,25$ and calculated in dependence on ϑ and α . The analysis of the results has shown, that neglecting the lateral contraction leads in practically all cases to errors of not negligible magnitude, and in most cases these errors lead to results in the values of the obtained internal stress components smaller than their proper values (this case of error is indicated by + in the table below). The interval of error varies between 2 and 30%, for the considered case, that $\eta = 0,25$ is neglected. For the same value $\eta = 0,25$ the maximum reduced values of error are obtained for Q_L , M_Q and M_{LQ} (10 to 30%), for Q_L and M_L the error is slightly less (5–20% and 5–15%). It is noticeable that if η is neglected in only some parts of the analysis, this does not lead to better agreement with the proper results, but can – on the contrary – lead to even greater errors (sometimes of more than dangerous importance) than if η is neglected throughout. Especially sensitive in this respect are the stress components M_Q , M_{LQ} , and Q_Q , where the error which results due to neglecting η only in the boundary condition or only in the formula defining the respective stress component can reach tens or even hundreds of percents. All calculation procedures which neglect or take into account the parameter η only in some parts of the calculation are therefore quite inadequate. When it is not possible to perform the exact calculation, it is better to assume $\eta = 0$ throughout, keeping in mind the possible magnitude of error as indicated above.

When lateral contraction is taken into account throughout, the analysis of shape orthotropic plane structures shows, that the internal stress components are not evenly distributed over the width even if the load is of uniform distribution across the width. The factor K_0 (evaluated by means of the indicated method for the indicated method for the case of evenly distributed load or by taking the integral of the influence surface of the factor K) defines the deflection; for some

values of ϑ , α , and η , and for two locations in the corsection $\varphi = \pi$ and $\varphi = \pi/4$ the value $(1+K^\circ)$ is given in a further table 3 below.

Table 2. Maximum reduced values of error in %

	α	ϑ					η neglected in
		0,05	0,25	0,5	1,0	2,0	
M_L	0	0	+4%	←-----→	+10%	-----→	boundary condition formula for M_L throughout
		0	+4%	←-----→	+10%	-----→	
	1		+8%	←-----→	+13%	-----→	boundary condition formula for M_L throughout
		0	+8%	←-----→	+13%	-----→	
M_Q	0	+5625%	+232%	+72%	+37%	+5%	boundary condition formula for M_Q throughout
		-6007%	-255%	-85%	-50%	-17%	
	1	+1466%	+80%	+38%	+24%	+9%	boundary condition formula for M_Q throughout
		-1583%	-104%	-56%	-39%	-21%	
M_{LQ}	0			0			boundary condition formula for M_{LQ} throughout
				0			
	1	+46%	+40%	←-----→	+35%	-----→	boundary condition formula for M_{LQ} throughout
		+28%	+23%	←-----→	+15%	+13%	
Q_L	0	0	+4%	←-----→	+10%		boundary condition formula for Q_L throughout
		0	+4%	←-----→	+10%		
	1	-24%	-17%	←-----→	-8%		boundary condition formula for Q_L throughout
		-24%	-17%	←-----→	-8%		
Q_Q	0	-1519%	-65%	-28%	-22%	-10%	boundary condition formula for Q_Q throughout
		0	±1%	±3%	±3%	<±2%	
	1	+11%	+10%	+7%	+4%	+2%	boundary condition formula for Q_Q throughout
		±11%	±10%	±7%	±4%	<±2%	
\bar{Q}_L	0	0	+3%	←-----→	+10%	-----→	boundary condition formula for \bar{Q}_L throughout
		0	+4%	←-----→	+10%	-----→	
	1	-65%	-48%	←-----→	-30%	-----→	boundary condition formula for \bar{Q}_L throughout
		+11%	-39%	←-----→	+7%	-----→	
		-64%	-39%	←-----→	-30%	-----→	

Table 3. Errors in the factor $(1+K^0)$ due to neglect of $\eta = 0,25$

ϑ	η	$\varphi = \pi$			$\varphi = \pi/4$		
		$\alpha = 0$	$\alpha = 0,5$	$\alpha = 1$	$\alpha = 0$	$\alpha = 0,5$	$\alpha = 1$
0,5	0	1,000	1,000	1,000	1,000	1,000	1,000
	0,25	1,243	1,154	1,114	0,989	1,000	1,004
1,0	0	1,000	1,000	1,000	1,000	1,000	1,000
	0,25	1,340	1,184	1,127	0,947	0,978	0,991

Comparison shows that with increasing η the absolute value of the deflection at the edge of the bridge and in its neighbourhood decreases (the decrease being indirect proportion to ϑ and indirect proportion to α), which shows that also the distribution of internal stress cannot be uniform across the width. The effect of lateral contraction upon the deflections and the stress components can be thus – even in the case of load iniformly distributed across the width – considerably important in a number of cases of practical interest.

REFERENCES

- [1] Bareš R., Massonnet Ch. – le calcul des grillages de poutres et dalles orthotropes selon la methode Guyon – Massonnet – Bareš, DUNOD, Paris, 1966
- [2] Bareš R. – Analysis form–orthotropic plane system by the method of dimensionless parameters, Acta Technica ČSAV, No. 5,6, 1973
- [3] Bareš R. – Vypočet tvarove ortotropnich plošnych konstrukci metodou bezrozmernych součinitelů, Bericht ITAM–TSAW, Prag, 1971
- [4] Bareš R. – Biegungs – und Torsionssteifigkeiten von Flachentragwerken mit Erwagung der Querkontraktionen, VDI–Z, No. 3, 1974
- [5] Cornelius W. – Die Berechnung der ebenen Flachentragwerke mit Hilfe der Theorie der orthogonal – anisotropen Platte, Stahlbau 2, 1952, pp.21–24, 43–48, 60–63
- [6] Girkmann K. – Flachentragwerke, 5. Ed., Wien, 1959.
- [7] Guyon Y. – Calcul des ponts larges a poutres multiples solidarisees par des entretoises, Ann. des Ponts et Chaussees de France, No.9, 10, 1946, pp.553–612
- [8] Guyon Y. – Calcul des pont–dalles, Ann. des Ponts et Chaussees de France, 1949, pp. 555–589, 683–718
- [9] Huber MT. – Ueber die genaue Berechnung einer orthotropen Platte, Bauingenieur 7, 1925,, p.7
- [10] Little G., Rowe R. – Load distribution in multi–webbed bridge structures from tests on plastic models, Mag. of Concrete Res. 7, 1955, No. 21
- [11] MassonnetCh. – Methode de calcul des ponts a poutres multiples tenant compte de leur resistance a la torsion, Memoires A.I.C.P. 10, 1950, pp.147–182
- [12] Massonnet Ch., Dehan E., Seyvert J. – Recherches experimentales sur les ponts a poutres multiples, Ann. Trav. Publ. de Belgique 107, 1954, No. 5

- [13] Roesli A., Walter R. — The analysis of prestressed multi-beam bridges as orthotropic plates, *The Civil Engineer* 12, 1958, No.3,4
- [14] Sattler K. — Betrachtungen zum Berechnungsverfahren von Guyon—Massonnet für freilegende Trägerroste und Erweiterung dieses Verfahrens auf beliebige Systeme, *Bauingenieur* 30, 1955, No.3

SUMMARY

The method presented here shows an exact and very expeditious approach to the analysis of shape orthotropic plane structures of the bridge type; the calculations are very clear and simple, so that the desired results are quickly obtainable. The analysis is based on the analogy to the solution of a true plate (with material orthotropy) by means of the governing Huber equation. With the presented method it is possible to take into account the lateral contraction capacity, which is expressed by a special parameter, so that the lateral contraction of the individual members and their interaction with regard to the deformations of the structure as a whole can be calculated without any difficulties. Some formulas leading to better (more correct) values of the flexural and torsional rigidities have been also given, derived by the author elsewhere; these formulas have been derived with due regard to the influence of lateral contraction, and it is shown, what errors can arise in the various phases of the calculation when lateral contraction is neglected. It appears, that the influence of lateral contraction may be of utmost importance with some of the new materials, which possess considerably high values of the Poisson coefficients (plastics, light alloys, composites, etc.).

Richard Bareš, Eng. (Civ.), Ph.D., Chief Research Scientist, Head of Department of Nonhomogenous Medias, Institute of Theoretical and Applied Mechanics of Czechoslovak Academy of Sciences, Vršbřadská 49, 128 49 Prague 2

it

XII JUGOSLOVENSKI KONGRES RACIONALNE I PRIMENJENE MEHANIKE
XII ЮГОСЛАВСКИЙ КОНГРЕСС ПО РАЦИОНАЛЬНОЙ И ПРИКЛАДНОЙ МЕХАНИКЕ
12TH YUGOSLAV CONGRESS OF RATIONAL AND APPLIED MECHANICS

Sekcija: C3

C3 - 2 Analysis of structurally orthotropic plane systems

R. B a r e š

Much theoretical /1,5,6,11,14/ and experimental /10,12,13/ research has been published which has given proof that the analysis of structurally orthotropic plane structures can be successfully based on the analogy to the solution of a true, materially orthotropic plate by means of the Huber equation /9/; it has also been shown that the results furnished by such an approach are reliable, unless the basic assumptions are too oversimplified. Simplicity, clarity possibility of good insight into the structure at any phase of the calculation are the main advantages of the method of analysis as derived by the present author /2,3/ on the basis just described. With the author's method it is possible to take into account also the not insignificant factor of lateral contraction, which up to the present has been mostly neglected in technical calculations. The Huber equation is solved by the method of dimensionless coefficients, similarly as in /1,8,11/. The values of these coefficients can be calculated beforehand, and the numerical work can be best handled by means of automatic computers. Once the coefficients have been tabulated, the analysis of any given structure with defined dimensions can easily worked out by the designer.

The structural (or shape-) orthotropy of a plate is given either by different reinforcement or different degree of prestress in two mutually perpendicular direction, or by rigidly connecting the plate to beams in the longitudinal or the transverse or in both these directions, respectively. Structural orthotropy results also from intentional prevention or reduction of force transfer in the transverse direction (assembled structures of pre-cast elements). The true plate with material orthotropy presents thus one limiting case, while in the other limiting case the structure consists only of two systems of beams /longitudinal main beams and cross beams). According to the overall arrangement as well as to the relative importance of the individual elements (plate or slab, prismatic members, etc.) the influence of torsion and lateral contraction upon the internal state of stress varies appreciatedly.

Principles of the method

The static response of a shape orthotropic plane structure shown in fig. 1 is - when the "diaphragm" effect is neglected - given by the Huber equation, which for the equivalent plate can be written in the form /6/.

$$\rho_L \frac{\partial^4 W}{\partial x^4} + 2H \frac{\partial^4 W}{\partial x^2 \partial y^2} + \rho_Q \frac{\partial^4 W}{\partial y^4} = \rho(x, y) \quad (1)$$

where $2H = (\rho_L \nu_Q + \rho_Q \nu_L + \gamma_L + \gamma_Q)$ and $\rho_L, \rho_Q, \gamma_L, \gamma_Q$ are the unit rigidities in flexure and torsion for the longitudinal and the transverse direction, respectively. The factors ν_L and ν_Q express the stress-strain relations and their dependence on the structural orthotropy /6/.

All the sectional and material properties of the structure are determined by the following three dimensionless parameters:

the parameter of lateral stiffness $\nu^j = \frac{b}{l} \sqrt{\frac{\rho_L}{\rho_Q}}$ 17/ (range $0 \leq \nu^j \leq \infty$) (2)

the parameter of torsional stiffness $\alpha = \frac{\gamma_L + \gamma_Q}{2(1-\eta)\rho_L \rho_Q}$ 11/ (range $0 \leq \alpha \leq 1$) (3)

and

the parameter of lateral contraction $\eta = \nu_L \sqrt{\frac{\rho_Q}{\rho_L}}$ 12,3/ (range $0 \leq \eta \leq 0,5$) (4)

Using the factors α and η we can write

$$2H = 2E \sqrt{\rho_L \rho_Q} \quad (5)$$

where

$$E = [\eta + \alpha(1 - E)]$$

denotes the parameter of the middle term in the Huber equation ($0 \leq E \leq 1$). The location of the point where the effects are required and the location of a point-load are given by the dimensionless coordinates $\varphi = \frac{\pi y}{b}$, $\xi = \frac{\pi x}{l}$, and $\psi = \frac{\pi z}{b}$.

The solution of the governing Huber equation follows on the same pattern as has been derived in /1/; here, however, the factor η is consistently taken into account in the governing equation (in the factors $\rho_L \rho_Q, 2H$), as well as in boundary conditions (along the free edges) and in the expressions for internal stress components $M_L, M_Q, M_{LQ}, M_{QL}, Q_L, Q_Q, \bar{Q}_L$, the latter components being expressed in terms of the derivatives to the deflection w /9/. On performing the necessary operations and simplifying, we obtain for the system according to fig1, which is subjected to a line load parallel to X, the following expressions for the deflection and for the stress components:

the deflection

$$w_{(x,y)} = \sum_m \frac{p_m l^4}{26 m^4 \pi^3 \rho_L} \cdot \chi_{(y)_m} \sin \frac{m \pi x}{l} \quad (6)$$

the bending moment in longitudinal direction

$$M_L = \sum_m \frac{P_m \ell^2}{2b\pi m^2} \left\{ k_{(y)m} + \eta \mu_{(y)m} \right\} \sin \frac{m\pi x}{\ell}, \quad (7)$$

the bending moment in transverse direction

$$M_Q = \sum_m \frac{P_m \ell}{2\pi^2 m^2} \left[\eta k_{(y)m} + \mu_{(y)m} \right] \sin \frac{m\pi x}{\ell}, \quad (8)$$

the difference of twisting moments

$$(M_{LQ} - M_{QL}) = \sum_m \alpha (1 - \eta) \frac{P_m \ell}{2\pi m} \left[\tau_{(y)m} \right] \cos \frac{m\pi x}{\ell}, \quad (9)$$

the shear force in longitudinal direction

$$Q_L = \sum_m \frac{P_m \ell}{m 2b m} \left\{ k_{(y)m} + \left(\frac{\partial_Q}{\sqrt{\rho_L \rho_Q}} + \eta \right) \mu_{(y)m} \right\} \cos \frac{m\pi x}{\ell}, \quad (10)$$

the shear force in transverse direction

$$Q_Q = \sum_m P_m \left\{ \alpha_{(y)m} + \frac{1}{4} \left(\eta + \frac{\partial_L}{\sqrt{\rho_L \rho_Q}} \right) \tau_{(y)m} \right\} \sin \frac{m\pi x}{\ell}, \quad (11)$$

and, finally

$$\bar{Q}_L = \sum_m \frac{P_m \ell}{m 2b m} \left\{ k_{(y)m} + (2\varepsilon - \eta) \mu_{(y)m} \right\} \cos \frac{m\pi x}{\ell} \quad (12)$$

the reactions in longitudinal direction.

In these formulas the symbols k , μ , τ , and α are dimensionless coefficients given by the expressions

$$k_{(y)m} = \frac{m \nu^2}{\sqrt{2(1+\varepsilon)}} \left\{ [A'_m M_{\varphi m} + \bar{B}'_m N_{\varphi m}] + [C'_m O_{\varphi m} + \bar{D}'_m P_{\varphi m}] + [O_{1\varphi-\psi 1m} + \alpha P_{1\varphi-\psi 1m}] \right\} \quad (13)$$

$$\begin{aligned} \mu_{(y)m} = & -\frac{m \nu^2}{\sqrt{2(1+\varepsilon)}} \left[\varepsilon (A'_m M_{\varphi m} + \bar{B}'_m N_{\varphi m}) + \sqrt{1-\varepsilon^2} (-A'_m N_{\varphi m} + \bar{B}'_m M_{\varphi m}) \right. \\ & + \varepsilon (C'_m O_{\varphi m} + \bar{D}'_m P_{\varphi m}) + \sqrt{1-\varepsilon^2} (C'_m P_{\varphi m} - \bar{D}'_m O_{\varphi m}) \\ & \left. + \sqrt{\frac{1+\varepsilon}{1-\varepsilon}} P_{1\varphi-\psi 1m} - O_{1\varphi-\psi 1m} \right]. \quad (14) \end{aligned}$$

$$C_{(y)m} = [A'_m M_{\varphi m} + \bar{B}'_m N_{\varphi m}] + \sqrt{\frac{1-\varepsilon}{1+\varepsilon}} [-A'_m N_{\varphi m} + \bar{B}'_m M_{\varphi m}] - \quad (15)$$

$$- [C'_m O_{\varphi m} + \bar{D}'_m P_{\varphi m}] + \sqrt{\frac{1-\varepsilon}{1+\varepsilon}} [-C'_m P_{\varphi m} + \bar{D}'_m O_{\varphi m}] +$$

$$+ \frac{2}{\sqrt{1-\varepsilon^2}} P_{|\varphi-\psi|m}$$

$$x_{(y)m} = -\frac{1}{4} [(2\varepsilon-1)(A'_m M_{\varphi m} + \bar{B}'_m N_{\varphi m}) - (2\varepsilon+1)\sqrt{\frac{1-\varepsilon}{1+\varepsilon}} \cdot \quad (16)$$

$$\cdot (A'_m N_{\varphi m} - \bar{B}'_m M_{\varphi m}) - (2\varepsilon-1)(C'_m O_{\varphi m} + \bar{D}'_m P_{\varphi m}) - (2\varepsilon+1)\sqrt{\frac{1-\varepsilon}{1+\varepsilon}} \cdot$$

$$\cdot (C'_m P_{\varphi m} - \bar{D}'_m O_{\varphi m}) + \left(\frac{2\varepsilon}{\sqrt{1-\varepsilon^2}} P_{|\varphi-\psi|m} - 2O_{|\varphi-\psi|m} \right)]$$

Similar expressions are obtained for the case of load evenly distributed over the width, or for the case when the structure is loaded by external transverse bending moments acting along the two free edges /2,3/.

It may be seen that once the dimensionless coefficients have been calculated, the rest of the calculation is quite simple, since it involves only a few algebraic operations. The dimensionless coefficients can be in any given case determined easily by means of a computer, where the program can be once for all set up and tuned beforehand. The coefficients can be also tabulated for specified characteristic values of the governing three parameters, and in this case the analysis of any given structure can be performed using the tabulated values together with the interpolation formulas given below. When the latter procedure is applied, see /1/, the calculation is facilitated by the elsewhere derived fact, that for any of the coefficients its respective value corresponding to the m -th term of the pertaining Fourier series is identic to its value pertaining to the first term of the series, but written for the reduced magnitude m^2 of the parameter of lateral stiffness. The dependence of all the coefficients on η and α can - as a further simplification - with sufficient accuracy be expressed (for all the characteristic points φ and points of load ψ) by means of the parabolic interpolation formula

$$X_k = X_{\min} + (X_{\max} - X_{\min}) F(k)$$

where X_k denotes the required value of the coefficient, for a given value of η or/and α at a specified point φ for the load at ψ , X_{\min} is the value of the coefficient for the minimum value of α , and/or η at the location φ for the load applied at ψ , X_{\max} is the value of the coefficient for the maximum value of α and/or η at the location φ for the load applied at ψ , $F(k)$ is a function dependent on α , η , φ , and ψ . It is thus possible to tabulate the coefficients only for limit values of α , η

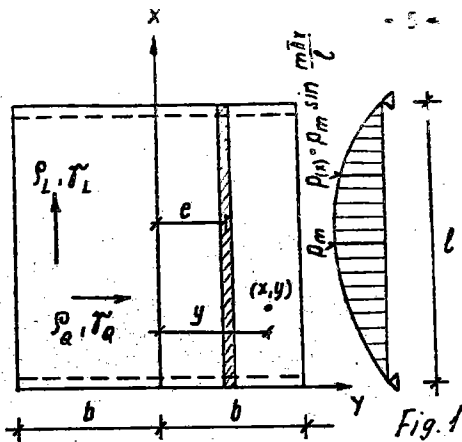

for a sufficiently dense net of φ, ψ and for various values of $\nu^B / 2,3/$.

If the difference of 2,5% in the true and the interpolated value is satisfactory, the factor $F(k)$ of interpolation for τ (which is best done first) is $F(k) = \sqrt{\alpha}$, while the factor of interpolation for α (when $\nu^B > 0,45$) is $F(k) = \sqrt{\alpha}$. For $\nu^B < 0,45$ the interpolation factors are given in the following table 1:

Table 1.

Dimensionless coefficient	Factor $F(k)$
K	$\alpha^{(-0,06 + 0,90 \nu^B)}$
α	for $\varphi, \psi \leq 0 : \alpha^{(-0,012 + 0,72 \nu^B)}$ for $\varphi, \psi = 0 : \alpha^{(1,07 - 1,21 \nu^B)}$
τ	for $\psi = 0 : \alpha^{(0,075 - 1,42 \nu^B)}$ for $\psi \neq 0 : \alpha^{(-0,053 + 0,88 \nu^B)}$
α	$\alpha^{(-0,045 + 0,70 \nu^B)}$

More accurate expressions for the interpolation functions $F(k)$ as well as the factors $F(k)$ for the case of evenly distributed load and for the case of external moment loading along the edges may be found in /3/.

Input data

In the analysis of a given actual structure, the flexural and torsional rigidities are introduced as input, and these given values may considerably influence the results of the calculations, even more than the method itself. One of the factors which also influence the interaction and composite work of the individual elements is the factor of lateral contraction.

When the analysis is based on the concept of the equivalent plate, which replaces - in the analysis - the true system, the flexural rigidity of the plate is proportional to the flexural rigidities of the true system. These latter rigidities are of course influenced by the prevented deformations in the perpendicular direction due to the action of some of the members. This effect resembles the case when the pertaining material constant $E_{ik} = \frac{E}{1-\nu}$ is raised; since the modulus of elasticity E (Young's modulus) itself does not change, the only change of the elastic constants E_{ik} can result from a change in the Poisson coefficients of lateral contraction; instead of the true Poisson factors ν_x, ν_y pertaining to the given structural material, the analysis is performed with their modified values ν_{L1}, ν_{R1} . Taking into account the influence of lateral contraction for example in the case of structure with stiffening ribs (see fig.2), /3,4/, we obtain the flexural rigidities as

follows:

in the longitudinal direction

$$\rho_L = \frac{E_0 J_{OX}}{b_0 (1-\nu_0^2) \left\{ d + \frac{1}{2} h_y \frac{b_1 (b_0 - b_1)}{b_0} \frac{\nu_{PRY}}{\nu_0} \right\}} + \frac{E_{PRY} J_{PRX}}{b_0 (1-\nu_0^2) \frac{b_1}{PRY h_x} \frac{l_1}{l_0} \left[\frac{5}{6} + \frac{1}{6} \frac{b_1}{b_0} \right] \frac{\nu_{PRY}}{\nu_{PRX}}} \quad (17)$$

in the transverse direction

$$\rho_Q = \frac{E_0 J_{OY}}{b_0 (1-\nu_0^2) \left\{ d + \frac{1}{2} h_x \frac{b_1 (b_0 - b_1)}{b_0} \frac{\nu_{PRX}}{\nu_0} \right\}} + \frac{E_{PRY} J_{PRY}}{b_0 (1-\nu_0^2) \frac{b_1}{PRY b_0} \left[\frac{5}{6} + \frac{1}{6} \frac{l_1}{l_0} \right] \frac{\nu_{PRX}}{\nu_{PRY}}} \quad (18)$$

With these values of ρ_L and ρ_Q we calculate next the parameter of lateral stiffness ν_Q .

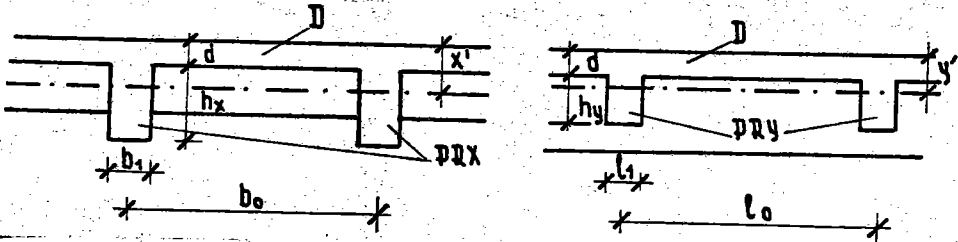

Fig. 2

Making use of the theorem of Betti /6/, we introduce $\nu_Q = \nu_L \frac{\rho_Q}{\rho_L}$ and write thus

$$\nu_L \nu_Q = \nu_L^2 \frac{\rho_Q}{\rho_L} = \eta^2. \text{ Then the parameter of lateral contraction } \eta \text{ follows directly from the flexural rigidity of the equivalent plate } \rho_L = \frac{\rho_L'}{1-\eta^2}, \text{ i.e. } \eta = \sqrt{\frac{\rho_L - \rho_L'}{\rho_L}};$$

the factor ρ_L' is the flexural rigidity in longitudinal direction if we assume that the Poisson factor for the material of the individual members are of zero value.

The main problem is to determine the torsional rigidity of the substitute structure is such a way as to interpret the actual conditions in the best possible manner; here we have to take into account not only the torsional rigidities of the elements but also the true flexural rigidity as a whole and also the lateral contraction. A simple investigation /2, 3/ (for example if we submit the limit shapes of the structure to the anticlastic test) shows immediately that simple summation of the individual torsional rigidities cannot be regarded as a satisfactory interpretation of the torsional rigidity of the structure as a whole, and the use of the sum of rigidities for instance in the strain energy methods can therefore not lead to acceptable results. The torsional rigidities and their mutual interaction are influenced by the capacity to transfer torsional or compressional stresses (the so called "fibre" effect), as well as by the capacity to transfer bending stresses (the so called "flexural" effect). The torsional rigidity of the substitute plate can be then expressed as /2,3/

$$\gamma_L = \frac{1}{2} \frac{1}{3} f h_L^3 \cdot a \frac{E_D}{2(1+\eta)} \quad (19)$$

$$\gamma_Q = \frac{1}{2} \frac{1}{3} f h_Q^3 \cdot b \frac{E_D}{2(1+\eta)} \quad (20)$$

where a , b are the coefficients of reduction, defined as

$$a = \sqrt{\frac{\sum (\mathcal{M}_{TRUE})_R \rho_Q}{\sum (\mathcal{M}_{MAX})_R (\rho_{MAX})_R}} \quad (\leq 1) \quad (21)$$

$$b = \sqrt{\frac{\sum (\mathcal{M}_{TRUE})_L \rho_L}{\sum (\mathcal{M}_{MAX})_L (\rho_{MAX})_L}} \quad (\leq 1) \quad (22)$$

Here - the symbols $\sum (\mathcal{M}_{TRUE})_R$ and $\sum (\mathcal{M}_{TRUE})_L$ denote the absolute value of the sum of static moments of the actual elements located in the transverse or longitudinal section above or under the corresponding central axis, the static moments being taken with respect to the pertaining axis;

- the symbols $\sum (\mathcal{M}_{MAX})_R$ and $\sum (\mathcal{M}_{MAX})_L$ denoted the absolute value of the sum of static moments of the parts of the full slab sections, located in the transverse or longitudinal section above or under the corresponding central axis, the moments being again taken with respect to the pertaining axis;

- the factors ρ_L, ρ_Q are the flexural rigidities, calculated in the manner indicated above;

- $(\rho_{MAX})_R = (\rho_{MAX})_L$ is the flexural rigidity of the full slab whose depth is equal to the maximum depth of the true structural section.

With these values of γ together with the factors ρ, η found above we are able to calculate the dimensionless parameter α .

To illustrate the case we have shown in fig.3 the variation of the torsional parameter α for a concrete slab stiffened by differently spaced and differently deep ribs. It may be seen that simply cutting the slab (cuts of infinitesimal width) to the depth equal to some 4/5 of overall depth, the parameter is reduced up to less than one third of the original value, though the volume of the structure has not been changed. Also with increased spacing of the longitudinal and transverse beams the values of α decreases rapidly. For example when the depth of the longitudinal and the transverse beams is the same, and $b_0/b_1 = l_0/l_1 = 5$, then - for the slab depth equal to 1/5 of the overall depth - the torsional parameter α is approximately equal to 1/3, while with the usual assumption (i.e. summing up the individual rigidities of the elements and then distributing the obtained value over the width and length of the structure) the torsional rigidity is obtained considerably smaller (up to 0,1 approximately). Of great influence is naturally the decreasing of depth of the transverse beams; thus for the limit case that the transverse stiffness is due only to the slab (i.e. there are no transverse beams) and when the longitudinal beams are wide apart ($b_0/b_1 = 5$) the torsional parameter value of lateral

stiffness is $\alpha = 0,12$. All the above given values of α are much better in accordance with experimental results obtained by the anticlastic test, than the α - values calculated with the usual methods.

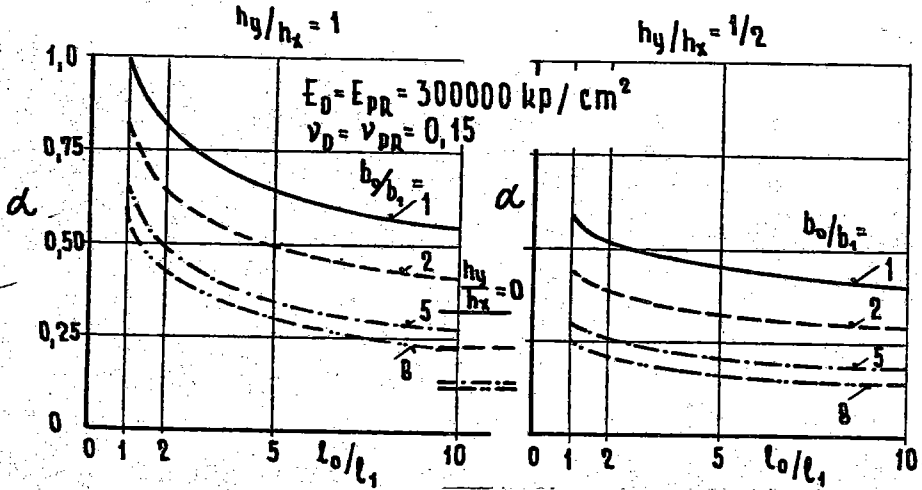

Fig. 3

Effect of lateral contraction

When the lateral contraction, as expressed by the parameter η , is neglected in constants of integration (pertaining to the solution of the governing equation) as well as in the expressions for the respective internal stress components, this results in certain errors, which can be defined by a method derived by the author; thus also the magnitude of error implicated in the existing usual methods of analysis can be ascertained. By a suitable transformation of formulas (6)-(12) for the internal stress components it is possible to find the magnitude of error which arises due to neglecting the parameter in the governing equation and in the boundary conditions, or which arises due to neglecting the parameter η only in the formulas for internal stress components, or - finally - the error which results if η is neglected throughout. In the table 2 below we have given the maximum errors for the internal stress components (reduced weighted average according to the relative weight of the individual stress components for specified values of ν^A and α) which arise due to neglecting the parameter η ; the errors have been related to the chosen value $\eta = 0,25$ and calculated in dependence on ν^A and α . The analysis of the results has shown, that neglecting the lateral contraction leads in practically all cases to errors of not negligible magnitude, and in most cases these errors lead to results in the values of the obtained internal stress components smaller than their proper values (this case of error is indicated by + in the table below). The interval of error varies between 2 and 30%, for the considered case, that $\eta = 0,25$ is neglected. For the same value $\eta = 0,25$ the maximum reduced values of error are obtained for Q_T , M_B , and M_{in} (10 to 30%), for Q_L and M_L the error is slightly less (5-20% and 5-15%). It is noticeable that if η is neglected in only

some parts of the analysis, this does not lead to better agreement with the proper results, but can - on the contrary - lead to even greater errors (sometimes of more than dangerous importance) than if η is neglected throughout. Especially sensitive in this respect are the stress components M_L , M_{1L} , and Q_L , where the error which results due to neglecting η only in the boundary condition or only in the formula defining the respective stress component can reach tens or even hundreds of percents. All calculation procedures which neglect or take into account the parameter η only in some parts of the calculation are therefore quite inadequate. When it is not possible to perform the exact calculation, it is better to assume $\eta = 0$ throughout, keeping in mind the possible magnitude of error as indicated above.

When lateral contraction is taken into account throughout, the analysis of shape orthotropic plane structures shows, that the internal stress components are not evenly distributed over the width even if the load is of uniform distribution across the width. The factor K^0 (evaluated by means of the indicated method for the case of evenly distributed load or by taking the integral of the influence surface of the factor K) defines the deflection; for some values of ν^j , α , and η , and for two locations in the cross-section $\varphi = \pi$ and $\varphi = \pi/4$ the value $(1 + K^0)$ is given in a further table 3 below.

Comparison shows that with increasing η the absolute value of the deflection at the edge of the bridge and in its neighbourhood decreases (the decrease being in direct proportion to ν^j and indirect proportion to α), which shows that also the distribution of internal stress cannot be uniform across the width. The effect of lateral contraction upon the deflections and the stress components can be thus - even in the case of load uniformly distributed across the width - considerably important in a number of cases of practical interest.

Table 2. Maximum reduced values of error in %

	α	ν^j					η neglected in
		0,05	0,25	0,5	1,0	2,0	
M_L	0	0	+4%	← -7% →	+10%	→	boundary condition formula for M_L
		0	+4%	← -7% →	+10%	→	throughout
	1	+8%	← -7% →	+13%	→	boundary condition formula for M_L	
		0	+8%	← -7% →	+13%	→	throughout
M_Q	0	+562%	+232%	+72%	+37%	+5%	boundary condition formula for M_Q
		-6007%	-255%	-85%	-50%	-17%	throughout
	1	+1462%	+80%	+38%	+24%	+9%	boundary condition formula for M_Q
		-1583%	-104%	-56%	-39%	-21%	throughout
		+28%	+28%	+25%	+22%	+20%	

Table 2. - continued

	α	ν^{λ}					η neglected in
		0,05	0,25	0,5	1,0	2,0	
M_{1Q}	0	$\leftarrow \begin{matrix} 0 \\ 0 \\ 0 \end{matrix} \rightarrow$					boundary condition formula for M_{1Q}
	1	+46%	+40%	$\leftarrow -33\% \rightarrow$	+35%	\rightarrow	throughout
		+28%	+23%	+17%	+15%	+13%	boundary condition formula for M_{1Q}
							throughout
Q_L	0	$\leftarrow \begin{matrix} 0 \\ 0 \end{matrix} \rightarrow$					boundary condition formula for Q_L
	1	-24%	-17%	$\leftarrow -11\% \rightarrow$	-8%	\rightarrow	throughout
		-24%	-17%	-11%	-8%		boundary condition formula for Q_L
							throughout
Q_Q	0	-1519%	-65%	-28%	-22%	-10%	boundary condition formula for Q_Q
	1	0	$\pm 1\%$	$\pm 3\%$	$\pm 3\%$	$\angle \pm 2\%$	throughout
		+11%	+10%	+7%	+4%	+2%	boundary condition formula for Q_Q
		$\pm 11\%$	$\pm 10\%$	$\pm 7\%$	$\pm 4\%$	$\angle \pm 2\%$	throughout
\bar{Q}_L	0	$\leftarrow \begin{matrix} 0 \\ 0 \end{matrix} \rightarrow$					boundary condition formula for \bar{Q}_L
	1	-65%	-48%	$\leftarrow -30\% \rightarrow$	+7%	\rightarrow	throughout
		+11%	+4%	+10%			boundary condition formula for \bar{Q}_L
		-64%	-39%	-30%			throughout

Table 3. Errors in the factor $(1 + k^0)$ due to neglect of $\eta = 0,25$

ν^{λ}	η	$\psi = \pi$			$\psi = \frac{\pi}{4}$		
		$\alpha = 0$	$\alpha = 0,5$	$\alpha = 1$	$\alpha = 0$	$\alpha = 0,5$	$\alpha = 1$
0,5	0	1,000	1,000	1,000	1,000	1,000	1,000
	0,25	1,243	1,154	1,114	0,989	1,000	1,004
1,0	0	1,000	1,000	1,000	1,000	1,000	1,000
	0,25	1,340	1,184	1,127	0,947	0,978	0,991

Summary

The method presented here shows an exact and very expeditious approach to the analysis of shape orthotropic plane structures of the bridge type; the calculations are very clear and simple, so that the desired results are quickly obtainable. The analysis is based on the analogy to the solution of a true plate (with material orthotropy) by means of the governing Huber equation. With the presented method it is possible to take into account the lateral contraction capacity, which is expressed by a special parameter, so that the lateral contraction of the individual members and their interaction with regard to the deformations of the structure as a whole can be calculated without any difficulties. Some formulas leading to better (more correct) values of the flexural and torsional rigidities have been also given, derived by the author elsewhere; these formulas have been derived with due regard to the influence of lateral contraction, and it is shown, what errors can arise in the various phases of the calculation when lateral contraction is neglected. It appears, that the influence of lateral contraction may be of utmost importance with some of the new materials, which possess considerably high values of the Poisson coefficient (plastics, light alloys, composites, etc.).

References

- /1/ Bareš R., Massonnet Ch. - Le calcul des grillages de poutres et dalles orthotropes selon la méthode Guyon - Massonnet - Bareš, DUNOD, Paris, 1966
- /2/ Bareš R. - Analysis form-orthotropic plane system by the method of dimensionless parameters, Acta Technica ČSAV, No.5,6, 1973
- /3/ Bareš R. - Výpočet tvarově ortotropních plošných konstrukcí metodou bezrozměrných součinitelů, Bericht ITAM-TSAA, Prag, 1971
- /4/ Bareš R. - Biegungs- und Torsionssteifigkeiten von Flächentragwerken mit Erwägung der Querkontraktionen, VDI-Z, No.3, 1974
- /5/ Cornelius W. - Die Berechnung der ebenen Flächentragwerke mit Hilfe der Theorie der orthogonal - anisotropen Platte, Stahlbau 2, 1952, pp.21-24,43-48,60-63
- /6/ Girkmann K. - Flächentragwerke, 5.Ed., Wien, 1959
- /7/ Guyon Y. - Calcul des ponts larges à poutres multiples solidarisées par des entretoises, Ann. des Ponts et Chaussées de France, No. 9,10, 1946, pp.553-612
- /8/ Guyon Y. - Calcul des pont-dalles, Ann. des Ponts et Chaussées de France, 1949, pp.555-589, 683-718
- /9/ Huber M.T. - Ueber die genaue Berechnung einer orthotropen Platte, Bauingenieur 7, 1925, p.7
- /10/ Little G., Rowe R. - Load distribution in multi-webbed bridge structures from tests on plastic models, Mag. of Concrete Res. 7, 1955, No.21
- /11/ Massonnet Ch. - Méthode de calcul des ponts à poutres multiples tenant compte de leur résistance à la torsion, Mémoires A.I.C.P. 10, 1950, pp.147-182
- /12/ Massonnet Ch., Dehan E., Seyvert J. - Recherches expérimentales sur les ponts à poutres multiples, Ann. Trav. Publ. de Belgique 107, 1954, No.5

- /13/ Roesli A., Walter R. - The analysis of prestressed multi-beam bridges as orthotropic plates, The Civil Engineer 12, 1958, No.3,4
- /14/ Sattler K. - Betrachtungen zum Berechnungsverfahren von Guyon-Massonnet für freiliegende Trägerroste und Erweiterung dieses Verfahrens auf beliebige Systeme, Bauingenieur 30, 1955, No.3

Richard B a r e š, Eng.(Civ.),PhD., Chief Research Scientist, Head of Department of Nonhomogenous Medias, Institute of Theoretical and Applied Mechanics of Czechoslovak Academy of Sciences, Vyšehradská 49,128 49 Prague 2